



From Manual Reading to Intelligent Monitoring By IoT

Sinchana¹, Kavyashree B², Pavithra K³ & Angel Deepa M.⁴

1. II Year BCA, Christ College Mysore. Email: sinchana99457@gmail.com
2. II Year BCA, Christ College Mysore. Email: kavyabalu2307@gmail.com
3. II Year BCA, Christ College Mysore. Email: skandaa16@gmail.com
4. Assistant Professor, Christ College, Mysuru. Email: mariaangeldeepa@gmail.com

Abstract: *Accurate billing and efficient energy management depend on electricity metering. Both digital and conventional meters mainly rely on manual procedures, which can lead to inaccurate billing, delayed data collection, human error, and a lack of consumer awareness regarding electricity usage. Both end users and meter readers are impacted by these problems. This project introduces an Internet of Things (IoT)-based smart electricity meter that incorporates machine learning techniques to address these shortcomings. The system continuously measures voltage, current, and power consumption using embedded sensors and transmits real-time data via wireless communication to a cloud platform. Machine learning models identify anomalous energy behavior, forecast future consumption, examine usage trends, and offer astute suggestions for effective power use. All things considered, the suggested solution boosts energy efficiency, facilitates deployment, increases billing accuracy, and improves transparency. This project demonstrates how IoT and ML technologies can transform conventional electricity metering into an intelligent, automated, and user-centric energy management solution. This strategy encourages consumer to use energy responsibly and lowers operating costs for utilities. All things considered, the solution supports sustainable and effective electricity management and is in line with smart grid goals. In order to guarantee data integrity, secure communication protocols are used. Furthermore, the suggested system eliminates the need of physical meter inspections by enabling automated data logging and remote meter reading.*

Keywords: *Energy Management, IoT, Embedded Sensors, and Machine Learning Models.*

Introduction: In many places, traditional electricity meters are still used. These meters need a person to come to the house and write down the reading manually. Because of this, sometimes there can be mistakes in writing or calculating the bill. Some users also face problems like wrong billing, delay in getting the bill, and no clear idea about how much electricity they are using daily. If the meter reader misses a visit, the bill may be delayed, which can create confusion or extra charges. People also cannot track their usage in real time, so they only know about high consumption after they receive a big bill.

Smart meters help to solve many of these problems. Smart meters will automatically send the reading to the electricity department, so there is no need for manual checking. This reduces human errors and gives more accurate bills. Users can see their electricity usage in real time through mobile apps or online portals. This helps them understand how much power they are using and control their usage to save money. Smart meters

also help in faster detection of power cuts or technical issues, which improves overall service. Because the data is sent automatically, billing becomes more transparent and reliable. Smart meters are an important step towards modern and efficient energy management. They reduce mistakes, save time, and give better control to both the users and the electricity providers. As technology is growing, moving from traditional meters to smart meters . It help in better energy savings and smarter cities in the future. With reference to, International Energy Agency (IEA) on smart grids and smart meters, and Ministry of Power (Government of India) about smart meter implementation in India, we can understand that by using smart meters we can improve billing accuracy and reduce power losses. These reports clearly show that smart meters help in better energy planning, reduce electricity theft, and improve customer service. Overall, shifting from manual meters to smart meters is not just a technical change, but a step towards better energy management and smarter living. With proper awareness and support, smart meters can help both consumers and electricity providers in the long run.

Literature Survey: [1] IEC IEEE Access – LoRa IoT-Based AMI for Smart Meters, this paper proposes an IoT-based smart metering architecture using LoRa for advanced metering infrastructure (AMI) in residential smart grid environments, highlighting how low-power wide-area network (LPWAN) technologies help transmit meter data efficiently for utility management and consumption monitoring. The study shows that combining IoT communication reduces errors and supports real-time data collection, though challenges remain for large-scale deployment.

[2] Appliance Detection Using Very Low-Frequency Smart Meter Time Series (ACM e-Energy 2023), this research evaluates different time series classification methods applied to low-frequency (30 min) smart meter consumption data to detect the presence of specific household appliances. Results show that deep learning approaches outperform traditional classifiers in accuracy and scalability, indicating the growing importance of AI techniques in smart meter analytics.

[3] DF & TransApp: Transformer Framework for Smart Meter Data (VLDB 2024), Adrien Petralia et al. developed a transformer-based machine learning model (TransApp) integrated with an appliance detection framework (ADF) for smart meter data. They demonstrate that weakly supervised and deep learning methods significantly improve appliance detection accuracy from aggregated electricity readings, advancing the use of smart meter data for personalized energy insights.

[4] Smart Energy Meters for Smart Grids – IoT Perspective (Energies 2023), this article provides an overview of smart energy meters within smart grids from an IoT perspective, stressing how advanced sensing, communications, and cloud processing enable precise monitoring and management of power consumption. It highlights key technological trends improving smart grid performance and smart meter integration.

[5] Smart Meter Feedback & Residential Behaviour (2025), A recent review examines how smart meter feedback influences energy-efficient behaviour in residential buildings, noting that real-time alerts and AI-enabled feedback can reduce consumption, though long-term engagement remains challenging. This highlights the social impact of smart metering beyond hardware.

[6] Edge-Based Energy Efficient Smart Metering (IEEE TSUSC 2021), this paper proposes an energy-efficient smart metering system using edge computing with LoRa networks, optimizing the selection of communication parameters to reduce data size and transmission power. It demonstrates that edge processing enhances network efficiency, showing a trend toward distributed computing in smart meter systems.

[7] Research on Smart Meter Technology Evolution (2024 preprint), this paper reviews the evolution of smart meter technology from analog devices to intelligent IoT-enabled systems, highlighting how communication, computing, and sensing advancements have shaped the capabilities of modern smart meters and their integration with smart grids.

[8] An analysis of smart meter technologies for efficient energy management in households and organizations(2022): The study highlights the benefits of smart meter technology for both consumers and companies while revealing that some important user groups are being overlooked in current rollout plans. It also stresses the need for further research on technology acceptance and usage. The paper includes a detailed methodology with a literature review and SWOT analysis, presents findings based on evaluation criteria, critically discusses the results, and concludes by emphasizing the need for continued research in smart meter technology.

[9] A low-cost smart power meter for IoT(2019): The Internet of Things requires interconnected monitoring and actuating devices. Widespread dissemination of meters is crucial. IoT Smart Meter fundamental features are communication, low cost, and accuracy. Monitoring electrical consumption with low cost device accuracy.

[10] Ensuring power quality and demand-side management through IoT-based smart meters in a developing country(2022): A low-cost smart meter (SM) is proposed for developing countries. Suitable for the nations where a smart grid is yet to be deployed. The smart meter is capable of ensuring power quality. Demand-side management (i.e., direct load control) can be achieved through the SM.

[11] Automating Electric Power Consumption with a Smart Electricity Meter(2024): The development of radio electronics in the 21st century supports automation and real-time monitoring through wireless communication. In smart homes and smart cities, Internet of Things (IoT) devices help optimize energy usage by monitoring power consumption. This improves efficiency, reliability, safety, and environmental performance. A smart meter system with a wireless extension module can collect and send data to cloud platforms like SmartThings for analysis. Using this data, algorithms can provide recommendations to reduce energy use. Experimental results show that such systems are effective, easy to integrate with existing setups, and economically beneficial.

[12] IoT-Based Electric Monitoring System for Smart Electric Meter Application(2022): This paper presents an IoT-based electricity monitoring system designed to support smart electric meters by allowing consumers to track their real-time energy usage. Although smart meters were installed to improve billing accuracy, many users reported higher electricity bills after replacing conventional meters, leading to concerns. Investigations confirmed that the smart meters were functioning correctly, but dissatisfaction remained. To address this, the proposed system enables users to independently monitor and verify their electricity consumption, helping them compare it with the monthly bill provided by the energy supplier.

Issues and Difficulties in Traditional meters:

1. Human error: Mistakes can occur during recording or billing.
2. Limited data: Only provides periodic totals (monthly/quarterly), not detailed usage patterns.
3. Delayed detection: Leaks, theft, or abnormal consumption are noticed late.
4. Accessibility issues: Meters may be in hard-to-reach places, making readings inconvenient.
5. No remote monitoring: Requires physical presence, which is inefficient for large properties.
6. Manual effort: Readings must be taken by hand, which is time-consuming and labor-intensive.

Methodology: In this paper, IoT technology is used to convert manual electricity reading into an intelligent monitoring system. The smart meter collects electrical parameters such as voltage, current, power consumption (kWh), and power factor. These values are continuously measured by the digital energy meter.

The collected data is sent to a microcontroller like NodeMCU (ESP8266), which processes the readings. Using a Wi-Fi connection, the data is transmitted to a cloud server. The cloud platform stores the data in a database and updates it at regular intervals. Users and electricity providers can access this data through a web

dashboard or mobile application. The system also analyzes the data to calculate daily and monthly consumption. If the usage crosses a set limit, an alert message is generated. In this way, IoT enables real-time monitoring, automatic data storage, and remote access.

Implementation: The implementation of the smart meter system includes both hardware and software technologies. In hardware, we use a digital energy meter to measure electrical parameters and a microcontroller such as ESP8266/NodeMCU for processing and communication. A Wi-Fi module is used for internet connectivity. In some cases, sensors and relay modules can also be added for load control.

In software, IoT platforms like ThingSpeak, Blynk, or Firebase are used for cloud data storage and visualization. Programming is done using Embedded C or Arduino IDE to control the microcontroller. The system uploads the collected data to the cloud, where it is displayed in graphical format for easy understanding.

By integrating these technologies, the smart meter system provides accurate, automatic, and real-time electricity monitoring.

System Architecture: The system architecture of the smart meter consists of four main parts: Smart Meter Unit, Communication Network, Cloud Server, and User Interface. First, the smart meter unit includes a digital energy meter and a microcontroller (ESP8266/NodeMCU). The energy meter measures electrical parameters like voltage, current, and power consumption. The microcontroller collects this data and prepares it for transmission. Next, the communication network uses Wi-Fi to send the data from the smart meter to the cloud server. The data is transmitted at regular time intervals. The cloud server stores the received data in a database and processes it to calculate daily and monthly usage. It also checks if the consumption crosses the set limit and generates alerts. Finally, the user interface (mobile app or web dashboard) allows users and electricity providers to view real-time readings, usage history, and notifications. This architecture ensures automatic data collection, secure storage, and easy remote monitoring of electricity consumption.

Case studies:

Case Study 1 – Mumbai: In Mumbai, many residents faced the problem of receiving unusually high electricity bills even though their usage was normal. This happened because traditional electricity meters require manual reading by meter readers. In some cases, the meter reader mistakenly recorded the wrong numbers or used estimated readings when the meter was not easily accessible. As a result, the electricity consumption was recorded higher than the actual usage. This led to overbilling, where consumers were charged for more units than they had actually used. After complaints from residents, electricity authorities rechecked the meters and corrected the bills. This situation clearly showed how human errors in manual meter reading can cause financial burden to consumers.

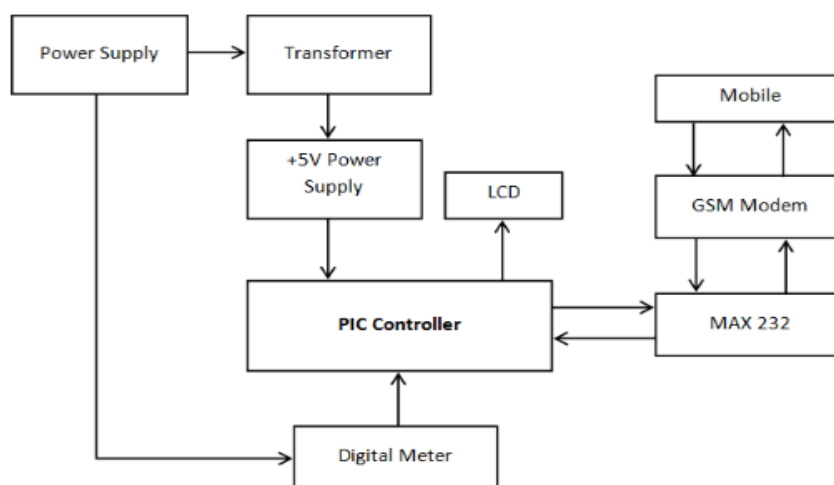

Fig 1.1 Smart Meter Block Diagram

Case Study 2 – Bengaluru: In Bengaluru, some households received very high electricity bills from BESCOM despite using electricity normally. When consumers raised complaints, it was discovered that the issue was caused by human error during meter reading and data entry. The meter reader had either noted the wrong reading or entered incorrect data into the system. Because of this mistake, the billed units were much higher than the actual electricity consumed. After inspection, officials verified the correct meter reading and issued revised bills. This real-life incident highlighted how manual meter systems depend heavily on human accuracy, and even small mistakes can result in significant overcharging.

Conclusion: Smart meters are an important step toward modernizing the electricity system. Unlike traditional meters, they automatically record energy consumption and send data to both consumers and electricity providers in real time. This helps in accurate billing, reduces manual work, and improves energy management. They support better monitoring of electricity usage, encourage consumers to save energy, and help detect faults or power theft quickly. Smart meters also play a key role in building smart grids and promoting efficient use of power. Even though challenges like high installation and maintenance costs exist, the long-term benefits such as improved efficiency, transparency, and reliable power supply make smart meters a valuable investment for the future. Overall, smart meters contribute to energy conservation, cost savings, and the development of a smarter and more sustainable power system.

References:

- A low-cost smart power meter for IoT. (2019).
- An analysis of smart meter technologies for efficient energy management in households and organizations. (2022).
- Appliance detection using very low-frequency smart meter time series. (2023). *ACM International Conference on Future Energy Systems (ACM e-Energy 2023)*.
- Automating electric power consumption with a smart electricity meter. (2024).
- DF & Tran SAPP: Transformer framework for smart meter data. (2024). *Proceedings of the VLDB Endowment*.
- Edge-based energy efficient smart metering. (2021). *IEEE Transactions on Sustainable Computing*.
- Ensuring power quality and demand-side management through IoT-based smart meters in a developing country. (2022).
- IEC IEEE access – LoRa IoT-based AMI for smart meters. (n.d.). *IEEE Access*.
- IoT-based electric monitoring system for smart electric meter application. (2022).
- Research on smart meter technology evolution. (2024). *Preprint*.
- Smart energy meters for smart grids: IoT perspective. (2023). *Energies*.
- Smart meter feedback and residential behaviors. (2025).

Citation: Sinchana, Kavyashree B, Pavithra K & Angel Deepa M., (2026) “From Manual Reading to Intelligent Monitoring By IoT”, *Bharati International Journal of Multidisciplinary Research & Development (BIJMRD)*, Vol-4, Issue-04(2), April-2026.